

H Scale – Data Sheet



HS-A shown with additional shackles

The H scale combines the proven R320 indicator with an S cell in an extended enclosure creating a compact trade approved sling scale – ideal for a wide range of weighing applications ranging from tea, flour to steel merchants, recycling and competition fishing - applications that require suspended weighing.

Peak hold functionality makes for an excellent load testing, cable pulling or tension device.

HS-A hanging scale

- Stainless steel load cell
- Stainless steel hook and eyes
- **Capacity** - 300kg (700lb)
- Single and dual range

Trade Builds

	Range 1		Range 2	
kg	300	0.10	150	0.05
lb	700	0.20	500	0.10



Underside view shown with IP65 battery boot option

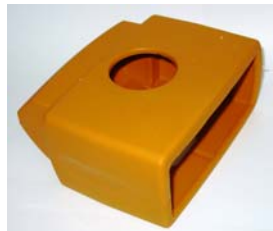

Protective silicon boot

built to last

- Safety rated fittings
- Positive locked fittings for safety and security
- Weather resistant housing (IP65)
- Pivoting mount arrangement makes swivelling the assembly and load simple.



proven R320 indicator

Clear highly visible display

20mm (0.8") LCD display with LED backlight

High contrast, improves operator visibility and accuracy of reading the weight.

Customise

Programmable function key

Peak Hold or Unit Switching
See Specifications for other functions.

Built in clock calendar

Allows for traceable dockets to be printed, requiring a less sophisticated printer, saving costs.

Built in communications and outputs

Built in RS232 communications

Connection to PC, printer and remote display

Two Isolated outputs

High side driver up to 300mA

Versatile power options

DC, Battery and AC Plug Pack

Protect lens over LCD

Durability maximised with the protective lens over the LCD to reduce risk of damage from knocks

Live Weigh Functionality

For weighing animals.

High Performance

Based on a 4,000d trade approved indicator

Pattern Approval

Australia NMI 6/13/3 3,000d

H Scale

Specifications

Product	HS-A				
Pattern Approval	NMI 6/13/3 3,000d				
Component Approvals	Indicator: OIML R76 4,000d, NTEP III/III L Indicator Medical: EN 60601-1-2: 2007 Load Cell: OIML R60 C3, OIML R60 C3, NTEP III/III L				
Trade Capacity	Range 1		Range 2		
	kg	300 0.10	150	0.05	
	lb	700 0.20	500	0.10	
Materials					
Hooks/Eyes	304 Stainless Steel				
Load Cell	Stainless Steel				
Indicator	ABS				
IP Rating	IP65				
Net Weight	3kg				
Indicator	R320				
Repeatability	+/- 1 division				
Linearity	+/- 1 division				
Display	LED Backlit LCD with six 20mm (0.8") high digits with units and annunciators				
Keypad	6 key silicon keypad				
Power Source					
DC	7 to 24VDC ON/OFF key with memory feature				
AC	AC plug pack Input: 110/240VAC 50/60Hz				
Battery	2.5Ah 12V NiMH rechargeable battery pack with IP65 boot Charger Input: 110/240VAC 50/60Hz Output: 12VDC Or 4 x AA batteries (Recommend rechargeable NiMH, NiCad, etc.)				
Ambient Temp	-10 to +50 °C ((14° to 122° F)				
Range	K302 Single – K305 Dual				
Serial Outputs	RS232 automatic transmit, network or printer outputs. Transmission rate: 2400, 4800 or 9600 baud				
Set points	2				
Assignable Func. Key	1				
Input/Outputs	1 Input 2 Outputs - isolated transistor drive outputs (up to 300mA each at 50VDC)				
Functions	Unit switching, counting, manual hold, peak hold, configurable printing and totalizing				

Specifications are subject to variation for improvement, without notice
Illustrations are indications only and variation may be evident between products

H Scale

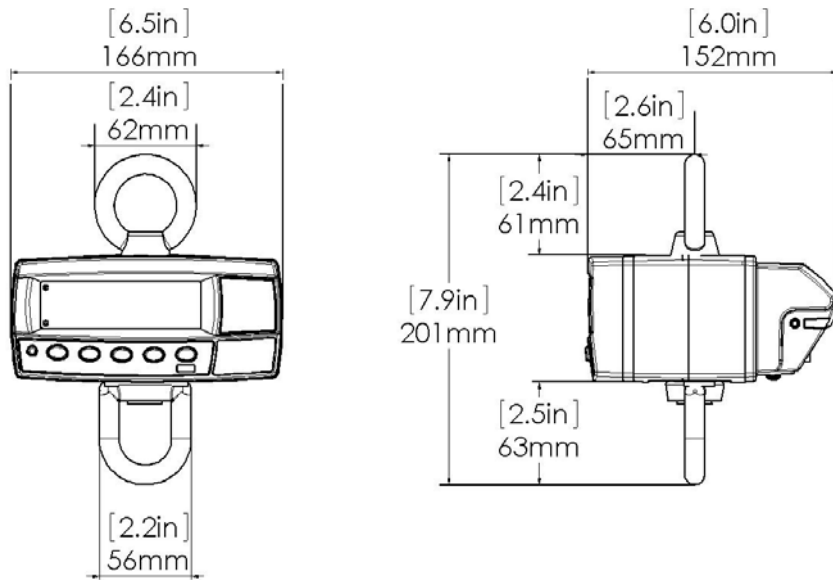

Stock Codes: Category C

H	S	Stainless steel loadcell
		3 0 0 300 kg
		A swivel eye on bottom and fixed eye on the top
		- R 3 2 0 R320 indicator fitted
		- K 3 0 2 standard software
		- K 3 0 5 dual range software
		- C DC
		- C * Plug Pack options
		- F * NiHM Internal Battery options
		- G * 4 AA Battery (R300) options
H	S	- - - A - - - - - K - - - - -

* Regional Power compatibility codes

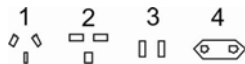

Rinstrum....now that's Smart Weighing

www.rinstrum.com



Australian Office
Rinstrum Pty Ltd
41 Success Street, Acacia Ridge
Queensland 4110 Australia
Phone +61 7 3216 7166
Fax +61 7 3216 6211
Email: sales@rinstrum.com



Proudly Sold & Serviced By:

Able Scale Co Pty Ltd

Ph: 1300 731 360

21 Green St Thomastown VIC. 3074

find us on the web: www.ablescale.com.au